

# CONTRACT CONDITIONS/ RULES & REGULATIONS

## TABLE OF CONTENTS

Eligibility Criteria for Exhibitors .....	2
Products Eligible for Exhibit.....	2
COVID-19 .....	2
Booth Cost.....	2
Assignment of Space.....	2
Payments, Cancellations & Refunds .....	3
Subletting of Exhibit Space Prohibited .....	4
Retail Sales .....	4
Intellectual Property Matters.....	4
Use of NAFEM Name .....	4
Set-up Time .....	5
Show Hours .....	5
Dismantling of Exhibits .....	5
Badges .....	5
Minimum Age for Admission .....	6
Exhibitor Liability, Indemnification & Insurance .....	6
Use of Space – General .....	6
Use of Space – Graphics.....	8
Use of Space – Food Preparation .....	8
Use of Space – Lights/Audio, etc .....	9
Displays Outside Exhibit Area .....	9
Hotel Rooms, Suites & Meeting Rooms .....	9
Fire Regulations .....	9
Labor Relations .....	10
Exhibitor Services Manual .....	10
Amendments/Interpretation .....	10
Enforcement/Miscellaneous .....	10
Limitation of Liability .....	10
Booth Construction.....	12
Booth Construction Rules & Regulations At-A-Glance .....	12
Standard Inline Booth Construction.....	13
Corner Booth Construction .....	13
Perimeter Booth Construction .....	13
Peninsula Booth Construction .....	14
Split Island Booth Construction .....	14
Modified Peninsula Booth Construction.....	15
Island Booth Construction .....	15
Important Considerations .....	16
Canopies & Ceilings, Hanging Signs, Multi-story Exhibits.....	16
Structural Integrity, Flammable & Toxic Materials, Storage .....	17

1.

**ELIGIBILITY CRITERIA FOR EXHIBITORS**

Exhibitors can be members or non-members of NAFEM, but they must meet NAFEM’s eligibility criteria.

The primary business of the Exhibitor is:

- Market and sell Approved Products manufactured in a facility which is owned or co-owned, or to which manufacturing is outsourced, by the entity, or
- Market and sell Approved Products which are manufactured by an entity related to it through a minimum of 50 percent ownership or 50 percent common ownership (the “Related Entity”).

A. The entity or its Related Entity must own or have an exclusive license to use the brand shown on the product or packaging of the Approved Products which constitute its primary business.

B. Approved Products are those products listed on the **NAFEM Approved Product Category List**, as may be amended from time-to-time by NAFEM in its sole discretion.

C. The product(s) may not appear in any other Exhibitor’s booth at The NAFEM Show.

D. The Exhibitor must have been in business for at least one year manufacturing and selling products before applying for exhibit space.

2.

**PRODUCTS ELIGIBLE FOR EXHIBIT**

The products shown in a booth must be on the **NAFEM Approved Product Category List**. The list may be found on the NAFEM website. If the Exhibitor meets the criteria listed in Section 1, it may exhibit a product on the Approved Product Category List which it does not manufacture, only if the products are branded under its name or trademark. The brand may be shown on the product or its packaging. Any product(s) not on the Approved Product Category List may not be displayed and must be removed from the Show Floor immediately upon notification of the infraction. Should the size of the product prohibit its immediate removal from the Show Floor, the product must be removed by the end of show hours on the day of infraction notification. Failure to comply will result in NAFEM closing the exhibit for the remainder of the show.

3.

**COVID-19**

The coronavirus pandemic poses risk to those attending large, in-person gatherings. To see the precautions NAFEM is taking, please visit [thenafemshow.org/show-info/covid-19-plan/](http://thenafemshow.org/show-info/covid-19-plan/).

4.

**BOOTH COST (No increase from 2019)**

**NAFEM Members**

- \$30/sq. ft.
- \$250 corner fee
- \$3,000 aisle fee

**Non-Member Exhibitors**

- \$3,500 non-member fee (non-refundable)
- \$40/sq. ft.
- \$250 corner fee
- \$3,000 aisle fee

5.

**ASSIGNMENT OF SPACE**

For all contracts and deposits received on or before March 31, space is assigned the weeks of April 19 and April 26 via online space selection in the following order:

1. NAFEM members with **200 points or more**, in priority point order, **the week of April 19**. For member companies with the same priority point status, a random drawing shall determine the order.
2. NAFEM members with **less than 200 points**, in priority point order, **the week of April 26**. For member companies with the same priority point status, a random drawing shall determine the order.
3. NAFEM Associate members in the order their contract was received. The Associate member categories eligible for booth space are:

- Education and Training Providers
- Food Safety Product Manufacturers
- Systems/Technology Integrators and Providers
- Third-Party Certification Organizations/Utility Organizations
- Trade Publications

4. Non-members in the order their contract was received.

For all contracts received after March 31, space will be assigned on a first-come, first-served basis starting the week after the online space selection is complete. Contracts and company name changes are not accepted after July 30.

Members: For a complete explanation of how priority points are earned, log in to the **“Member Dashboard”** section of the NAFEM website and select “Important Links and Documents”. A NAFEM member must continuously maintain membership through the show and pay all other amounts due to NAFEM (membership dues) to retain its space assignment.

**IMPORTANT**

Related companies exhibiting together may use the priority points of the member with the highest points. Related companies are those related through 50 percent ownership or 50 percent common ownership. All related companies that select booth space together must be listed in the exhibitor directory and on the floor plan. Related companies exhibiting separately must each use their own priority points to determine space assignment priority.

Non-related member companies may exhibit together and utilize the averaged total of their combined priority points provided that they purchase contiguous (above, below, diagonal or directly across the aisle from) booths. Contiguous booths cannot be adjacent across aisles that are greater than 10' wide (i.e. main aisles).

**For space assignments made after the online space selection, only companies that have an ownership relationship can exhibit together.**

**All contracts and deposits for related or non-related companies exhibiting together must be received before space can be assigned together.**

If an Exhibitor is acquired by another Exhibitor after its initial space selection, the acquired Exhibitor can move to the acquiring Exhibitor's booth without financial penalty. Alternatively, the acquired Exhibitor may retain its contracted space to show its own products and also may display the company name of the acquiring Exhibitor but not the acquiring Exhibitor's products.

Exhibitors that manufacture walk-in coolers, refrigerators and freezers and select inline booth(s) are required by NAFEM to purchase a booth with a depth of 15' (4.57m). Exhibitors that manufacture walk-in coolers, refrigerators and freezers must submit a detailed floor plan with dimensions, including height, of all items in the booth to Show Management for review and approval by July 2. Floor plans can be submitted through the Exhibitor Console or sent via email to [info@thenafemshow.org](mailto:info@thenafemshow.org).

No Exhibitor shall occupy more than one peninsula space. Islands and peninsulas (also referred to as end caps) less than 400 sq. ft are not permitted. Each Exhibiting company must have contiguous (above, below, diagonal or directly across the aisle from) booths.

Contiguous booths cannot be adjacent across aisles that are greater than 10' wide (i.e. main aisles). During the show, NAFEM controls the aisle(s), air space, and unsold booths/service aisles in the convention center. Exhibitors are not allowed a display of such design or construction which suggests aisles, service aisles or unsold booths are part of their exhibit area. Exhibitors are not permitted to have bridges over aisle space, or to use carpet in public aisles.

As an alternative to peninsula space, Exhibitors may use back-to-back booths in the center of an island creating a modified peninsula. The backwall shall be centered and is not to exceed 4' (1.12m) in height within 5' (1.52m) of the aisle and 10' (3.05m) in height in the center. This arrangement is based on a six-booth minimum. See diagram on page 15.

The reverse side of any wing panel or backwall must be draped or otherwise decorated so that these exposed areas will not be objectionable to adjacent Exhibitors. NAFEM reserves the right to require furnishings or masking drapery be installed, billing charges to the Exhibitor.

**All Exhibitors should frequently review their space location, changes to neighboring booths/areas and updates to the floor plan. It is the Exhibitor's responsibility to keep up with changes to their assigned area. NAFEM anticipates alterations to the initial plan and cannot be held responsible for changes that may affect a participating Exhibitor's selection of space.**

**NAFEM maintains a waitlist for any Exhibitor who wishes to be placed in a different booth location after their initial selection. To be added to**

**the waitlist, submit your request in writing, including the requested size of space to [info@thenafemshow.org](mailto:info@thenafemshow.org). Exhibitors are added to the waitlist on a first-come, first-served basis based on the date and time of email receipt.**

**NAFEM reserves the right to change show hours, rearrange the floor plan and relocate any Exhibitor as necessary at any time.**

**6.****PAYMENTS, CANCELLATIONS, & REFUNDS**

Contracts must be accompanied by a 25 percent deposit of the total space rental charge. The remaining balance must be paid on or before June 30 via one of the following options:

- Pay remaining 75 percent by June 30; or
- Pay 100 percent upon contract submission; or
- Pay remaining 75 percent in three installments; 25 percent by April 30, 25 percent by May 28, and 25 percent by June 30

Contracts submitted on or after June 30 must be accompanied by payment in full. Contracts are not processed, nor space assigned, without the required payment. Credit card payments can be made online using American Express, Discover, MasterCard or Visa. Make all checks payable to The NAFEM Show and remit to the following address:

**The NAFEM Show – Exhibits  
161 N. Clark St., Ste. 2020  
Chicago, IL 60601 USA**

Cancellation of exhibit space must be directed in writing via a delivery service which provides confirmation of delivery (i.e., FedEx, UPS, etc.) to the NAFEM Exhibits Manager.

**The NAFEM Show – Exhibits  
161 N. Clark St., Ste. 2020  
Chicago, IL 60601 USA**

Cancellation also may be directed via email to [info@thenafemshow.org](mailto:info@thenafemshow.org), provided that the canceling Exhibitor obtains confirmation of NAFEM's receipt of the email on or before the cancellation deadline.

For cancellations of space received between the initial space selection and June 1, Exhibitor is responsible for, and NAFEM retains, 25 percent of the total space rental charge as a cancellation fee. Should an Exhibitor cancel a portion of their space between their initial space selection and June 1, Exhibitor is responsible for, and NAFEM retains, the 25 percent deposit on the canceled partial space as a cancellation fee.

Full payment is required and no refunds whatsoever are made on cancellations or reductions of space on or after June 2. Should an Exhibitor cancel even partial space on or after June 2, the Exhibitor is responsible for the full space rental charge for the originally contracted exhibit space.

If for any reason beyond NAFEM's control, NAFEM determines that The NAFEM Show must be canceled, shortened, delayed, or otherwise altered or changed, Exhibitor understands and agrees that NAFEM will use its best efforts to provide a full refund of rental fees paid to it by Exhibitor.

If, despite using its best efforts, NAFEM is not able to provide a full refund of rental fees due to its losses incurred in connection with the cancellation or change to The NAFEM Show, NAFEM may retain up to 5% of the rental fees paid to it by Exhibitor and will refund to Exhibitor the remaining balance of rental fees paid to it by Exhibitor.

Exhibitors acknowledge and agree that NAFEM shall not be responsible for any losses or damages Exhibitors may incur in connection with The NAFEM Show including, but not limited to, travel to the show, exhibit setup, lodging, freight and employee wages.

Exhibitor, as a condition of being permitted by NAFEM to be an Exhibitor in The NAFEM Show, agrees to indemnify, defend and

hold harmless NAFEM, its directors, officers, employees, agents and subcontractors from any and all loss which Exhibitor may suffer as a result of show cancellation, duration, delay or other alterations or changes caused in whole, or in part, by any reason outside NAFEM's control. The terms of this provision shall survive the termination or expiration of this Contract.

## 7.

### **SUBLETTING OF EXHIBIT SPACE PROHIBITED**

Exhibitors are prohibited from assigning or subletting a booth or any part of the space allotted to them nor shall they exhibit or permit to be exhibited in their space any products or advertising materials which are not a part of their own regular products, or which are not compatible with the purpose and/or character of The NAFEM Show as determined by NAFEM in its sole discretion. Further, Exhibitors shall not engage in any promotional activities which NAFEM determines to be outside the purpose and/or character of The NAFEM Show as determined by NAFEM in its sole discretion.

## 8.

### **RETAIL SALES**

No retail sales, where payment is received and product delivered, are permitted on the Show Floor at any time. Payment and/or orders may be taken for future delivery.

## 9.

### **INTELLECTUAL PROPERTY MATTERS**

The Exhibitor represents and warrants to NAFEM that no materials used in or in connection with their exhibit infringe the trademarks, copyrights (including, without limitation, copyrights in music and other materials used or broadcast by Exhibitor) or other intellectual property rights of any third party.

The Exhibitor agrees to immediately notify NAFEM of any information of which the Exhibitor becomes aware regarding actual or alleged infringement of any third party's trademarks, copyrights or other intellectual property rights. The Exhibitor agrees to indemnify, defend and hold NAFEM, its officers, directors, employees, agents, successors and assigns harmless from and against all losses, damages and costs (including attorney's fees) arising out of or related to claims of infringement by Exhibitor of the trademarks, copyrights and other intellectual property rights of any third party.

Notwithstanding the foregoing, NAFEM shall not be liable for and expressly disclaims all liability for infringement or alleged infringement of the trademarks, copyrights or other intellectual property of any third party arising out of the actions of any Exhibitors. The terms of this provision shall survive the termination or expiration of this Contract.

## 10.

### **USE OF NAFEM NAME**

NAFEM, The NAFEM Show and The NAFEM Show logo are registered trademarks belonging to the North American Association of Food Equipment Manufacturers. Participation by an Exhibitor in The NAFEM Show does not entitle the Exhibitor to use such names or logos, except that the Exhibitor may reference The NAFEM Show and use The NAFEM Show logo with reference to the Exhibitor's participation as an Exhibitor at The NAFEM Show. Participation in The NAFEM Show does not imply endorsement or approval by NAFEM of any product, service or participant and none shall be claimed by any participant.

**11.**

**SET-UP TIME**

Set-up of exhibits begins in the Orange County Convention Center at 8 a.m., Sunday, Aug. 22, based on a target move-in. If an exhibit is not set-up by 6 p.m., Wednesday, Aug. 25, NAFEM reserves the right to re-assign such space to another Exhibitor or to make such other use of the space as deemed necessary or appropriate. NAFEM reserves the right to set-up the exhibit or remove the freight from the booth at the Exhibitor’s expense. No refund will be made to the original contracting Exhibitor. NAFEM reserves the right to modify hours, in which case all Exhibitors will be notified.

**12.**

**SHOW HOURS**

**Thursday, Aug. 26**  
9 a.m. – 5 p.m.

**Friday, Aug. 27**  
9 a.m. – 5 p.m.  
Training Time 8 a.m. – 9 a.m.

**Saturday, Aug. 28**  
9 a.m. – 3 p.m.  
Training Time 8 a.m. – 9 a.m.

Training Time is the hour before the official 9 a.m. show opening on Friday, Aug. 27 and Saturday, Aug. 28 providing manufacturers with time to conduct product training for their channel partners and customers. NAFEM automatically distributes Training Time badges to all show registrants who are members of CFESA, FCSI and FCSI- The Americas, FEDA and all buying groups.

If you have an interest in scheduling an early meeting with an attendee, contact NAFEM to arrange for a Training Time badge. Without a Training Time badge, attendees do not have access to the Show Floor until 9 a.m. on all show days. Exhibitors who violate or facilitate the violation of this rule may, at the discretion of NAFEM, lose part or all of its company’s priority points, and may entirely lose the privilege of exhibiting in future NAFEM shows.

**13.**

**DISMANTLING OF EXHIBITS**

Exhibits are to be kept intact until show closing on Saturday, Aug. 28 at 3 p.m. No part of an exhibit shall be removed during the show without special permission from Show Management. Any Exhibitor who begins dismantling its display before the close of the show may lose part or all of its priority points and may entirely lose the privilege of exhibiting at future NAFEM shows.

All freight must be removed from the Orange County Convention Center by noon, Tuesday, Aug. 31. If exhibits are not removed by this time, NAFEM reserves the right to remove exhibits and charge the expense to the Exhibitor. All carriers must check-in by 10 a.m., Tuesday, Aug. 31.

**14.**

**BADGES**

Exhibitors are provided five (5) complimentary Exhibitor or Manufacturers’ Rep badges per 150 sq. ft. of exhibit space purchased, with a minimum of five (5) badges per company. See below for badge allotment per booth square footage:

Booth size in square feet	Number of complimentary badges
0-150	5
151-300	10
301-450	15
451-600	20
601-750	25
751+	25+(5) additional badges per 150 sq. ft.

Exhibitor badges are for full and part time employees and the Exhibitors’ Manufacturers’ Reps. Exhibitor and Manufacturers’ Rep badges allow access to the Show Floor during the following move-in, show and move-out hours:

- Sunday, Aug. 22 (move-in)**  
8 a.m. – 6 p.m.
- Monday, Aug. 23 (move-in)**  
8 a.m. – 6 p.m.
- Tuesday, Aug. 24 (move-in)**  
8 a.m. – 6 p.m.
- Wednesday, Aug. 25 (move-in)**  
8 a.m. – 6 p.m.
- Thursday, Aug. 26 (show day 1)**  
7 a.m. – 5 p.m.
- Friday, Aug. 27 (show day 2)**  
7 a.m. – 5 p.m.
- Saturday, Aug. 28 (show day 3)**  
7 a.m. – 9 p.m.
- Sunday, Aug. 29 (move-out)**  
8 a.m. – 5 p.m.
- Monday, Aug. 30 (move-out)**  
8 a.m. – 5 p.m.
- Tuesday, Aug. 31 (move-out)**  
8 a.m. – noon

Attendees do not have access to the Show Floor until 9 a.m. on show days unless they are attending Training Time provided by an exhibitor. Exhibitors and Manufacturers’ Reps who give their badges to an attendee in order for the attendee to gain access to the Show Floor prior to this time may, at the sole discretion of NAFEM, lose part or all of its company’s priority points, and may entirely lose the privilege of exhibiting in future NAFEM shows. NAFEM reserves the right to give a Show Floor pass to any Exhibitor, Manufacturers’ Rep or attendee in order to grant them access to the Show Floor at any time.

## 15.

**MINIMUM AGE FOR ADMISSION**

Children under the age of 16 are not permitted on the Show Floor nor can they be accompanied by an adult on the Show Floor at any time. No exceptions or refunds are made.

## 16.

**EXHIBITOR LIABILITY, INDEMNIFICATION & INSURANCE**

Exhibitor remains solely responsible for the safety of its property at all times during transit to and from the Show Floor and on the Show Floor. Neither NAFEM, its directors, officers, employees, agents, subcontractors nor management of the Show Floor (hereinafter "Show Management") are responsible for Exhibitor's property or any loss thereto from any cause.

EXHIBITOR HEREBY WAIVES AND RELEASES ANY CLAIM OR DEMAND IT MAY HAVE AGAINST ANY OF THE SHOW MANAGEMENT BY REASON OF ANY DAMAGE TO OR LOSS OF ANY OF ITS PROPERTY.

Exhibitor agrees that it will indemnify, defend and hold Show Management, NAFEM, their respective officers, directors, employees, agents and each of them, harmless from and against a) the performance or breach of this Contract including, but not limited to, acts of its employees, agents and contractors; b) the failure by Exhibitor, its employees, agents or contractors to comply with applicable laws, regulations and ordinances; and c) all claims on account of injury to any person or property to the extent that any such injury was caused wholly or in part by an act or omission of Exhibitor or any of its agents, employees, subcontractors, guests, licensees or invitees. This indemnification of Show Management by Exhibitor is effective unless such injury was caused by the sole gross negligence or willful misconduct of Show Management.

Exhibitor agrees that if Show Management or NAFEM is made a party to any litigation commenced by or against Exhibitor, or relating to this Contract or the premises leased hereunder, then EXHIBITOR WILL PAY ALL COSTS AND EXPENSES, including reasonable attorneys' fees, INCURRED BY OR IMPOSED UPON SHOW MANAGEMENT OR NAFEM BY REASON OF SUCH LITIGATION. THE TERMS OF THIS PROVISION SHALL SURVIVE THE TERMINATION OR EXPIRATION OF THIS CONTRACT.

Exhibitors are required to maintain and provide a certificate of insurance on or before July 2 evidencing the following:

1. General liability with limits not less than \$1M per occurrence, \$2M aggregate
2. Owned (if applicable), hired and non-owned auto liability with limits not less than \$1M per occurrence
3. Workers' compensation with state statutory limits
4. Employer's liability with limits not less than \$500k/\$500k/\$500k
5. Commercial umbrella liability with limits not less than \$1M
6. Personal property and equipment on a special form replacement cost basis

North American Association of Food Equipment Manufacturers (NAFEM), SmithBucklin Corporation and the Orange County Convention Center are to be listed as additional insureds on a primary and non-contributory basis with respect to general/auto/umbrella liability.

A waiver of subrogation must apply to all policies.

All carriers are to maintain an A.M. Best rating of not less than A-VII.

Exhibitors will not be permitted to set up their booth without submitting the proper certificates. Certificates should be sent to:

**The NAFEM Show – Exhibits  
161 N. Clark St., Ste. 2020  
Chicago, IL 60601 USA**

Or via email to [info@thenafemshow.org](mailto:info@thenafemshow.org)

## 17.

**USE OF SPACE – GENERAL**

A. No Exhibitor is permitted to display or distribute literature or any promotion outside the confines of the assigned exhibit space on the Show Floor. Distribution or display of promotional material in public areas of the Orange County Convention Center or meeting rooms is strictly prohibited. NAFEM also reserves the right to remove, at Exhibitor's cost, any promotional material or product deemed by Show Management as not suitable for display at The NAFEM Show.

**B. Exhibitors are prohibited from possessing, displaying or depicting any products or components or company names in their booth that could be interpreted as being a promotion or comparison (features, benefits, price) of another company.**

C. No exhibit is permitted that interferes with the use of other exhibits or impedes access to them or the free use of the aisles.

D. Distribution by Exhibitors, or their agents, of any printed materials, souvenirs or other articles shall be restricted to the Exhibitor's exhibit space. No noisemakers, helium balloons, lighter-than-air objects, gummed stickers or labels are permitted as handouts.

E. Any special promotions, music or stunts planned for the Show Floor, must be cleared with NAFEM. NAFEM reserves the right to designate specific days and hours during which special promotions and stunts may be conducted, if permitted at all.

F. NAFEM allows drawings, games of chance and raffles on the Show Floor. Exhibitors must abide by all Florida state statutes regarding various drawings, games of chance and raffles. See [www.flsenate.gov/statutes](http://www.flsenate.gov/statutes) for additional information regarding [Statute #849.094](#), which addresses drawings of chance by business organizations. Also refer to the Department of Business and Professional Regulations with the State of Florida at [www.myflorida.com](http://www.myflorida.com) for more information.

G. No animals are permitted in the Orange County Convention Center other than service animals.

H. Exhibitors must abide by all of the General Policies, Rules, and Regulations of the Orange County Convention Center, a copy of which is included in the Exhibitor Services Manual, made available to Exhibitors in May. To obtain these rules prior to May, go to [www.occc.net/exhibitor-guidelines-information](http://www.occc.net/exhibitor-guidelines-information). The Orange County Convention Center has reserved the right to update, change or amend its rules and regulations after publication in the Exhibitor Services Manual.

I. All Exhibitors are responsible for compliance with the Americans with Disabilities Act (ADA). The Exhibitor shall indemnify, defend and hold NAFEM, its directors, officers, employees, agents or subcontractors harmless from any consequences of Exhibitor's failure in this regard. The terms of this provision shall survive the termination or expiration of this Contract. For more information on the ADA and how to make your exhibit accessible to persons with disabilities, contact:

**U.S. Department of Justice**  
ADA,  
Civil Rights Division Disability Rights  
Section – NYAV  
950 Pennsylvania Avenue,  
NW Washington, D.C. 20530  
USA phone: +1.800.514.0301 (voice)  
+1.800.514.0383 (TTY)  
[www.ada.gov](http://www.ada.gov)

J. Any Exhibitor occupying an island, split island, peninsula or modified peninsula space or who manufacturers walk-in coolers, refrigerators and/or

freezers is required to submit a detailed floor plan, including dimensions, to Show Management for review and approval by July 2. All Exhibitors who received a written booth violation notice at The NAFEM Show in 2019 are required to submit a detailed floor plan, including dimensions, to Show Management for review and approval by July 2. Floor plans should be submitted through the Exhibitor Console or sent via email to [info@thenafemshow.org](mailto:info@thenafemshow.org).

K. Umbrellas and canopies are considered part of the overall booth components and may not protrude into the aisle.

L. Helium or other compressed gas tanks are not stored on the exhibit floor. Secure storage outside the facility must be arranged through the Orange County Convention Center. All lighter-than-air display items must be tethered and are considered part of the overall booth components. All items must be removed from the Orange County Convention Center at the close of the event. The Orange County Convention Center will assess a fee for retrieving any escaped lighter-than-air objects. Any Exhibitor wishing to display a lighter-than-air object must fill out an agreement with the Orange County Convention Center. Refusal to do so will result in the removal of the object from the facility at the Exhibitor's expense.

M. Attendee lists from The NAFEM Show are distributed ONLY by NAFEM and ONLY to exhibiting companies via the Exhibitor Registration Dashboard in the Exhibitor Console. Note: No other individual or organization is authorized to market or sell attendee lists. Such lists shall only be used for mailings of promotional material relating to an Exhibitor's booth at The NAFEM Show and shall not be reproduced, transferred or used in any other manner. In using such lists for mailings, Exhibitors must ensure compliance with all country, state and local laws and regulations including, but not limited to, the European Union's General Data Protection Regulations (GDPR) and the California Consumer Privacy Act (CCPA). The Exhibitor shall hold NAFEM, its directors, officers, employees, agents or subcontractors harmless from any consequences of

the breach of this provision by Exhibitor, its employees, agents or contractors. The terms of this provision shall survive the termination or expiration of this Contract.

N. onPeak is the ONLY official housing vendor for The NAFEM Show. To speak directly to an onPeak representative, call +1.855.203.6329 or email [NAFEM@onpeak.com](mailto:NAFEM@onpeak.com). Your exhibit contract must be submitted before housing reservations can be made. Note: onPeak does not make phone calls soliciting Exhibitors to book hotel rooms. If you are contacted by any other company regarding hotel reservations, contact The NAFEM Show at [info@thenafemshow.org](mailto:info@thenafemshow.org) or +1.312.245.1054 ext.5 immediately. NAFEM shall not be responsible for any damages or costs related to Exhibitors making hotel reservations via an unauthorized solicitation of hotel reservations.

O. The NAFEM Show suppliers can be identified by their use of the official NAFEM supplier seal. Any supplier who solicits an exhibitor without this seal, is not an official supplier for The NAFEM Show.



P. All booth personnel must be properly and modestly clothed.

Q. Exhibitors are permitted to serve non-alcoholic beverages in their booth during Show Floor hours. All beverages must be ordered through the exclusive caterer, Centerplate. Non-alcoholic beverages do not need to be served by a bartender.

R. Standing on chairs, tables or other rental furniture is prohibited. The furniture is not engineered to support standing weight.

S. All booth floors must be finished. Exposed concrete is not acceptable. Booth carpet order forms are included in the Exhibitor Services Manual or Exhibitors may bring their own floor covering.

T. Exhibitors, at NAFEM's sole discretion, are prohibited from taking videos and photographs of any booths on the Show Floor, other than their own. Aerial photography, videography or stunts of any kind by an Exhibitor, i.e. drones, are strictly prohibited. Registration and attendance at or participation in the show or NAFEM meetings and other activities constitutes an agreement by the Exhibitor on behalf of its employees, agents and contractors to NAFEM's use and distribution (both now and in the future) of the image or voice of Exhibitor, its employees, agents and contractors in photographs, videotapes, electronic reproductions, or audiotapes of such events and activities.

U. Exhibitors' booth equipment (i.e. walk-in coolers) or booth structure must not take up so much space within the booth area such that Exhibitor personnel are required to stand outside their official area. Exhibitors should consider this placement prior to selecting their space size, as the area must accommodate this rule.

V. Music at any function held in conjunction with this show is subject to applicable copyright and licensing fees charged by ASCAP and/or BMI. It is the sole responsibility of the Exhibitor to pay applicable fees. For more information about licensing fees, visit [www.ascap.com](http://www.ascap.com) or [www.bmi.com](http://www.bmi.com). The Exhibitor shall hold NAFEM, its directors, officers, employees, agents or subcontractors harmless from any consequences of the breach of this provision by Exhibitor, its employees, agents or contractors. The terms of this provision shall survive the termination or expiration of this Contract.

## 18.

### USE OF SPACE – GRAPHICS

A. **Hanging signs are permitted** in all peninsulas, modified peninsulas, split islands and island booths **to a maximum height of 20' (6.10m) to the top** of the sign. Hanging signs are NOT permitted in inline booths.

B. **All exhibit fixtures and booth structures are permitted to a maximum height of 16'** (4.88m) in all peninsulas, modified peninsulas, split islands and island booths.

C. All booth items such as products, literature, pens, shirts, etc., may display the Exhibitor's logo. Reference or logos of a distributor, dealer or supplier cannot be present in the booth.

D. An Exhibitor may list its NAFEM member company name and brands on booth signage and graphics.

E. Non-member Exhibitors may only list their company name on booth signage and graphics.

Exhibitor's booth. Exhibitors must purchase adequate exhibit space to accommodate food preparation spectators in its booth. No lines or excessive crowds are permitted outside the booths.

D. Food preparation and sampling must be conducted at least three (3') feet from the aisle, and in a safe, sanitary manner to protect attendees from risk of injury.

E. The Exhibitor must control all smoke, vapor and odors to the extent that they are not objectionable to other Exhibitors. Exhibitors also must provide sufficient sanitary containers to preclude contamination of the aisles and of neighboring exhibits. It is the responsibility of the Exhibitor to see that no food or beverage leaves the booth.

F. NAFEM has the right and power to impose a cease and desist order to stop further food preparation and sampling when, in its opinion, the rules are not being followed or the food and/or beverage preparation or demonstration has become objectionable for any reason.

G. One (1) 5-pound ABC fire extinguisher with a current tag from a licensed fire extinguisher contractor must be in the exhibit booth no more than 30' from any gas appliances, cooking, or open flame where cooking is permitted.

H. Centerplate, the official in-house caterer at the Orange County Convention Center, is the exclusive provider of food and/or beverage items at the Orange County Convention Center. If requested, Centerplate will allow Exhibitors to bring their own food and/or non-alcoholic beverage into the Orange County Convention Center for the sole purpose of equipment demonstration, provided the Exhibitor has signed and submitted Centerplate's sampling and waiver of liability form which can be found in the Exhibitor Services Manual or by emailing [info@thenafemshow.org](mailto:info@thenafemshow.org). If Centerplate is required to handle, store, refrigerate, transport, deliver, prepare, or service any of the demonstration food and beverage product brought in by the Exhibitor, charges apply. Only

## 19.

### USE OF SPACE – FOOD PREPARATION

A. Food preparation must be intermittent using no larger than a 2.0 ounce sample size to demonstrate how the appliance performs. Non-alcoholic beverage samples cannot exceed a 4.0 ounce sample size. Such preparation will be principally for the purpose of demonstrating the functionality and eye appeal of the equipment in operation.

B. Such preparation must not create noise to the extent that it is annoying to neighboring Exhibitors, or distracting to the conduct of business on the Show Floor.

C. Such preparation is for qualified, interested customers who wish to see the equipment perform, and who may, in turn, sample the product in the



food and/or non-alcoholic beverages used for Exhibitor’s equipment demonstration are permitted.

I. Any Exhibitor preparing food using a gas appliance, open flame, heat-producing or smoke-emitting device must be individually reviewed by the Orange County Convention Center Event Management and the Orange County Fire Marshal. All requests must be submitted in writing and include appropriate documentation. Submission details are included in the Exhibitor Services Manual.

**20.**  
**USE OF SPACE – LIGHTS/AUDIO, ETC.**

A. No spotlight may be directed toward the aisles or so directed that it proves to be irritating or distracting to neighboring Exhibitors or guests.

B. Droplights or special lighting devices must be hung at a level or positioned so as not to prove to be an irritant or distraction to neighboring Exhibitors or guests.

C. No strobe light effects are permitted.

D. Projectors, computer screens or TV screens must not cause people to block the aisle. Computer screens and TV screens are considered part of the overall booth components and may not protrude into the aisle.

E. To be considerate of other Exhibitors and guests, loud speakers or sound equipment operating at excessive volume is not permitted based on the 80/80 Rule: Any sound that consistently exceeds 80 decibels measured at the edge of an Exhibitor’s booth or is clearly identifiable more than 80 feet from that booth is considered objectionable.

F. No lighting, fixtures, lighting trusses, or overhead lighting is allowed outside the boundaries of the exhibit space. All lighting should be directed to the inner confines of the booth space. Lighting should not project onto other exhibits or aisles. Exhibitors intending to use

hanging light systems are required to submit a detailed floor plan with light locations and dimensions, including height of all items in the booth, to Show Management for review and approval by July 2.

G. Only sign and video wall supporting truss systems have no trim height limit. All signs and video walls can hang at a maximum height of 20’ from the floor to the top of the sign or video wall. The trim height limit for all other hanging structures is 20’.

H. All equipment – signs, products etc. must be designed safely and in an appropriate condition to be suspended. A structural engineer’s certification or signed seal of approval for structural integrity, pick-point ratings, certification for overhead suspension must be available upon request and may be required under certain conditions.

**21.**  
**DISPLAYS OUTSIDE EXHIBIT AREA**

Absolutely no exhibits are permitted outside the Orange County Convention Center. There are to be no displays in hotel rooms, hotel public areas or other facilities or areas contracted or used by NAFEM.

**22.**  
**HOTEL ROOMS, SUITES & MEETING ROOMS**

A. Exhibitors may make housing reservations after their Contract for Exhibit Space is completed and returned to NAFEM, beginning on Feb. 1.

B. NAFEM reserves the right to control all suites and meeting rooms in the Orange County Convention Center and in those hotels participating in the NAFEM housing block. These controls have already been set up with each property. The Meeting/Function Space

Application is included in the Exhibitor Console to submit requests for function space, including meeting and hospitality rooms. Exhibitors also may submit applications for meeting space online in the “For Exhibitors” section of the website. No meetings, private functions, including lunch meetings, or entertainment can be scheduled during show hours  
9 .am. - 5 p.m., Thurs., Aug. 26  
9 a.m. - 5 p.m., Fri., Aug. 27, and  
9 a.m. - 3 p.m., Sat., Aug. 28

No product displays or demonstrations are permitted in meeting rooms. Activities that conflict with the nature of The NAFEM Show are not permitted.

C. Suites and meeting rooms are assigned on a first-come, first-served basis and only to Exhibitors and organizations allied with NAFEM.

**23.**  
**FIRE REGULATIONS**

A. All materials used in exhibit booth(s) must be of a non-flammable nature. Electric signs and equipment must be wired to meet the specifications of the Orange County Convention Center and the Orange County Fire Marshal.

B. Any Exhibitor having equipment that produces heat, smoke or open flames as an integral part of product demonstration must provide ventilation, safety equipment and proper insulation and utility connections meeting all local fire regulations. Such Exhibitors must receive written approval of plans from the Orange County Convention Center, the Orange County Fire Marshal and NAFEM. A heat producing device form to request approval from the Orange County Fire Marshal is included in the Exhibitor Services Manual.

C. A complete list of all fire regulations is included in the Exhibitor Services Manual. The Orange County Fire Marshal has reserved the right to update, change or amend its rules and regulations after publication in the Exhibitor Services Manual.

24.

**LABOR RELATIONS**

A. Full-time employees of exhibiting companies may set up their own exhibits without assistance from the local union. Any labor services that may be required beyond what an Exhibitor's regular full-time employees can provide must be rendered by union personnel and can be ordered in advance through Freeman, the General Services Contractor. Proof of full-time employment status may be requested by the Union Steward of any personnel working in your booth.

B. If Exhibitors intend to use an Exhibitor Appointed Contractor (EAC) to install and/or dismantle their booth, the Exhibitor must register their EAC no later than July 28. EAC registration information is provided in the Exhibitor Console. An original Certificate of Insurance must be filed with NAFEM in order for any EACs to gain access to the Show Floor.

C. Exhibitors may hand carry their own materials into the exhibit facility. The use or rental of dollies, flat trucks and other mechanical equipment, however, is not permitted. Freeman, the General Services Contractor, controls access to the loading docks in order to provide for a safe and orderly move-in/out. Only full-time employees of the exhibiting company are allowed to hand carry items. Unloading and reloading at the dock of any and all contracted carriers is handled by Freeman. A dock is also provided for use by privately operated vehicles and is identified in the Exhibitor Services Manual.

25.

**EXHIBITOR SERVICES MANUAL**

In May, Freeman, the official General Services Contractor, distributes an Exhibitor Services Manual to each Exhibitor that provides Exhibitors with complete shipping instructions, production information, and other forms for all services needed during installation, show days and dismantle. If you have any questions in advance, send an email to [info@thenafemshow.org](mailto:info@thenafemshow.org).

26.

**AMENDMENTS/ INTERPRETATION**

NAFEM reserves the right to amend and enforce this Contract. Written notice of any amendments shall be given to each affected Exhibitor. Each Exhibitor, for itself, its agents and employees, agrees to abide by this Contract set forth therein, or by any subsequent amendments. NAFEM reserves the sole right to interpret this Contract. All interpretations are final and are not subject to review or appeal.

27.

**ENFORCEMENT/ MISCELLANEOUS**

This Contract will be enforced by NAFEM.

A. For any Exhibitor displaying product(s) that are not included in the NAFEM Approved Product Category List, who fails to comply with Sections 1 and 2 on page 2, the non-approved products or components will be removed from the Exhibitor's booth at the Exhibitor's expense and stored by Show Management until the show ends. At the discretion of NAFEM, the Exhibitor also may lose part or all of their priority points and may entirely lose the privilege of exhibiting in future NAFEM shows.

B. Any Exhibitor not abiding this Contract including, but not limited to, violation of booth construction/height rules, may, at the discretion of NAFEM, be required to modify their booth at their sole cost, and/or lose part or all of their priority points, and may entirely lose the privilege of exhibiting in future NAFEM shows.

C. This Contract is governed by Illinois law and the Exhibitor consents to the exclusive jurisdiction of the State and Federal courts seated in Cook County, Illinois, with respect to any action arising out of this Contract or The NAFEM Show. The parties explicitly acknowledge and agree that the provisions of this Contract are both reasonable and enforceable. However, the provisions of this Contract are severable and, as such, the invalidity of any one or more provisions shall not affect or limit the enforceability of the remaining provisions. Should any provision be held unenforceable for any reason, then such provision shall be enforced to the maximum extent permitted by law.

D. This Contract will be binding on the Exhibitor's heirs, successors and assigns.

28.

**LIMITATION OF LIABILITY**

IN NO EVENT SHALL THE ORANGE COUNTY CONVENTION CENTER, THE NAFEM SHOW, NAFEM, THEIR OWNERS, MANAGERS, OFFICERS OR DIRECTORS, AGENTS, EMPLOYEES, INDEPENDENT CONTRACTORS, SUBSIDIARIES AND AFFILIATES (COLLECTIVELY "NAFEM PARTIES") BE LIABLE TO THE EXHIBITOR OR ANY THIRD PARTY HIRED BY OR OTHERWISE ENGAGED BY THE EXHIBITOR FOR ANY LOST PROFITS OR ANY OTHER INDIRECT, SPECIAL, PUNITIVE, EXEMPLARY, INCIDENTAL OR CONSEQUENTIAL DAMAGES, INCLUDING ATTORNEY'S FEES AND COSTS, ARISING OUT OF THIS APPLICATION AND CONTRACT OR CONNECTED IN ANY WAY WITH USE OF OR INABILITY TO USE

THE SERVICES OUTLINED IN THIS APPLICATION AND CONTRACT OR FOR ANY CLAIM BY EXHIBITOR, EVEN IF ANY OF THE NAFEM PARTIES HAVE BEEN ADVISED, ARE ON NOTICE, AND/OR SHOULD HAVE BEEN AWARE OF THE POSSIBILITY OF SUCH DAMAGES. EXHIBITOR AGREES THAT NAFEM PARTIES' SOLE AND MAXIMUM LIABILITY TO EXHIBITOR, REGARDLESS OF THE CIRCUMSTANCES, SHALL BE THE REFUND OF THE EXHIBIT BOOTH FEE. EXHIBITOR AGREES TO INDEMNIFY AND DEFEND THE NAFEM PARTIES FROM ANY CLAIMS BROUGHT BY A THIRD PARTY HIRED BY, OR ENGAGED BY THE EXHIBITOR FOR ANY AMOUNT BEYOND THE EXHIBIT BOOTH FEE. FURTHER, EXHIBITOR AGREES TO PAY ALL ATTORNEY'S FEES AND COSTS INCURRED BY NAFEM PARTIES ARISING OUT OF, OR IN ANY WAY RELATED TO, THIS CONTRACT. EXHIBITOR SHALL BE SOLEY RESPONSIBLE FOR ITS ATTORNEY'S FEES AND COSTS.

**BOOTH CONSTRUCTION RULES AND REGULATIONS AT A GLANCE**

	Maximum Exhibit Height	Line of Sight	Hanging Sign Allowed?	Booth Drawing Required?	Included with Booth
<p><b>Inline Booth</b> Example: 10'x10', 10'x20', 12'x10', 15'x10'</p>	Maximum Back Wall Height of 8'	4' height restriction imposed on all exhibit fixtures within 5' of an aisle. When two (2) or more inline booths are used in combination as a single exhibit space, the 4' height limitation is applied only to that portion of exhibit space which is within 10' of an adjoining booth.	<b>NO</b>	<b>NO</b> – unless you manufacture a walk-in cooler, refrigerator or freezer OR received a booth violation at The NAFEM Show 2019	8' high back drape, 3' high side drape
<p><b>Corner Booth</b> Example: 10'x10' with only one neighboring booth</p>	Maximum Back Wall Height of 8'	4' height restriction imposed on all exhibit fixtures within 5' of an aisle. When two (2) or more inline booths are used in combination as a single exhibit space, the 4' height limitation is applied only to that portion of exhibit space which is within 10' of an adjoining booth.	<b>NO</b>	<b>NO</b> – unless you manufacture a walk-in cooler, refrigerator or freezer OR received a booth violation at The NAFEM Show 2019	8' high back drape, 3' high side drape
<p><b>Perimeter Booth</b> Example: 10'x10', 10'x20', 12'x10', 15'x10' with a building wall behind the booth</p>	Maximum Back Wall Height of 12'	4' height restriction imposed on all exhibit fixtures within 5' of an aisle. When two (2) or more inline booths are used in combination as a single exhibit space, the 4' height limitation is applied only to that portion of exhibit space which is within 10' of an adjoining booth.	<b>NO</b>	<b>NO</b> – unless you manufacture a walk-in cooler, refrigerator or freezer OR received a booth violation at The NAFEM Show 2019	8' high back drape, 3' high side drape
<p><b>Peninsula Booth</b> Example: 30'x30' which backs up to inline booths</p>	16' Maximum Height	When a peninsula booth backs up to two (2) inline booths, the backwall is restricted to 4' in height within 5' of the aisle and 10' of the adjoining booths.	<b>YES – Hung at maximum of 20' from the top of the sign to the floor</b>	<b>YES</b> – submit through your exhibitor console or to info@thenafemshow.org by July 2	8' high back drape
<p><b>Split Island Booth</b> Example: 20'x20' booth backing up to a neighboring 20'x20' booth</p>	16' Maximum Height in All Areas of Booth	No sight line restrictions	<b>YES – Hung at maximum of 20' from the top of the sign to the floor</b>	<b>YES</b> – submit through your exhibitor console or to info@thenafemshow.org by July 2	8' high drape set between booths, if requested
<p><b>Island Booth</b> Example: 20'x20', 20'x30', 30'x30', 30'x40'</p>	16' Maximum Height in All Areas of Booth	No sight line restrictions	<b>YES – Hung at maximum of 20' from the top of the sign to the floor</b>	<b>YES</b> – submit through your exhibitor console or to info@thenafemshow.org by July 2	N/A

**STANDARD INLINE BOOTH**

Inline booths have only one side exposed to an aisle and are generally arranged in a series along a straight line. Individual booths may be combined to form a larger inline exhibit space.

**Dimensions**

For purposes of consistency and ease of layout, all inline booths are 10' (3.05m) across the front. Inline booths are available in three depths, 10' (3.05m), 12' (3.66m) and 15' (4.57m).

**Use of Space**

Regardless of the number of inline booths utilized, e.g. 10' by 20' (3.05m by 6.10m), 10' by 30' (3.05m by 9.14m), 10' by 40' (3.05m by 12.19m) etc., exhibit fixtures should be arranged in such a manner as not to obstruct sight lines of neighboring Exhibitors. The maximum height of 8' (2.44m) is allowed in the rear of the exhibit space, with a 4' (1.22m) height restriction imposed on all exhibit fixtures within 5' (1.52m) of an aisle. When two (2) or more inline booths are used in combination as a single exhibit space, the 4' (1.22m) height limitation is applied only to that portion of exhibit space which is within 10' (3.05m) of an adjoining booth. Hanging signs are NOT permitted in standard inline booths.

View the inline booth rules and regulations video on the [NAFEM YouTube channel](#).

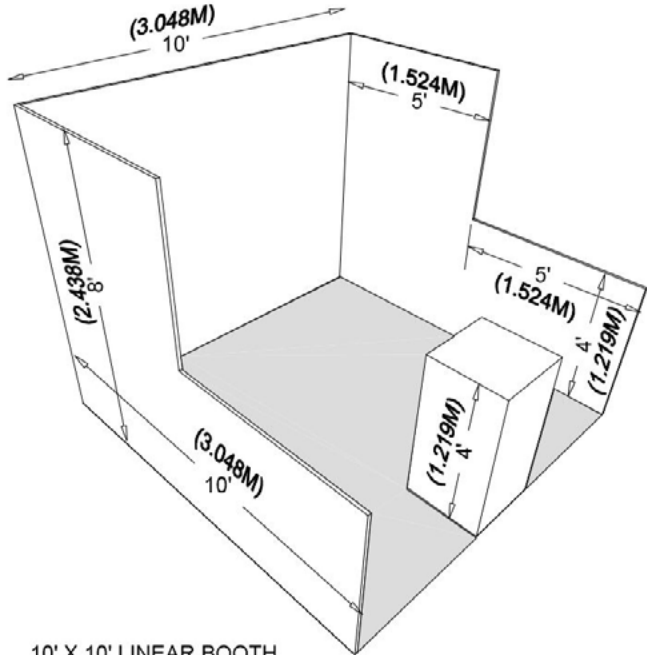

10' X 10' LINEAR BOOTH

**CORNER BOOTH**

A corner booth is an inline booth exposed to aisles on two (2) sides. All other guidelines for inline booths apply. Hanging signs are NOT permitted in corner booths.

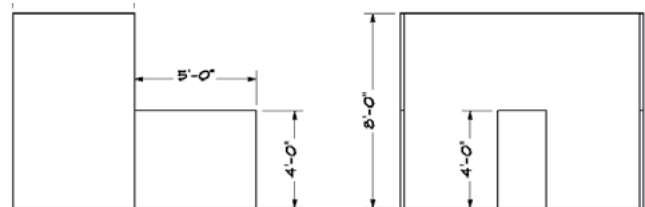

LEFT SIDE VIEW

RIGHT SIDE VIEW

**PERIMETER BOOTH**

A perimeter booth is an inline booth that backs up to any wall of the exhibit facility rather than to another exhibit. All guidelines for inline booths apply to perimeter booths with the exception that the maximum back wall height is 12' (3.66m). Hanging signs are NOT permitting in perimeter booths.

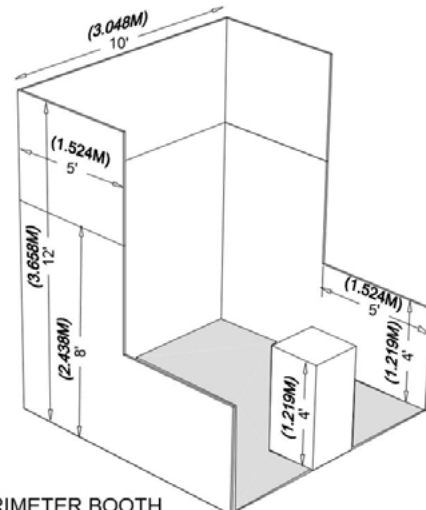

10' X 10' PERIMETER BOOTH

**PENINSULA BOOTH**

A peninsula booth is exposed to aisles on three (3) sides and composed of a minimum of four (4) booths. When combining booths to create a peninsula booth, any service aisle space becomes part of the usable exhibit space. Backwalls must be finished and cannot contain copy. There are two (2) primary types of peninsula booths: one which backs up to inline booths and one which backs up to another peninsula booth and is referred to as a split island booth.

**Dimensions**

A peninsula booth at The NAFEM Show is usually 30’ wide (9.14m). A limited number of 20’ wide (6.10m) peninsulas are available. When a peninsula booth backs up to two (2) inline booths, the backwall is restricted to 4’ (1.22m) in height within 5’ (1.52m) of the aisle and 10’ (3.05m) of the adjoining booths. **16’ (4.88m) is the maximum height allowance for the center portion of the backwall and exhibit fixtures. Hanging signs can be hung at a maximum height of 20’ (6.10m) to the top of the sign.** NAFEM will provide 8’ high drape for all peninsula booths.

Any Exhibitor occupying a peninsula booth is required to submit a detailed floor plan with dimensions, including height, of all items in the booth, including hanging signage, to Show Management for review and approval by July 2. Floor plans can be submitted through the Exhibitor Console or sent via email to [info@thenafemshow.org](mailto:info@thenafemshow.org).

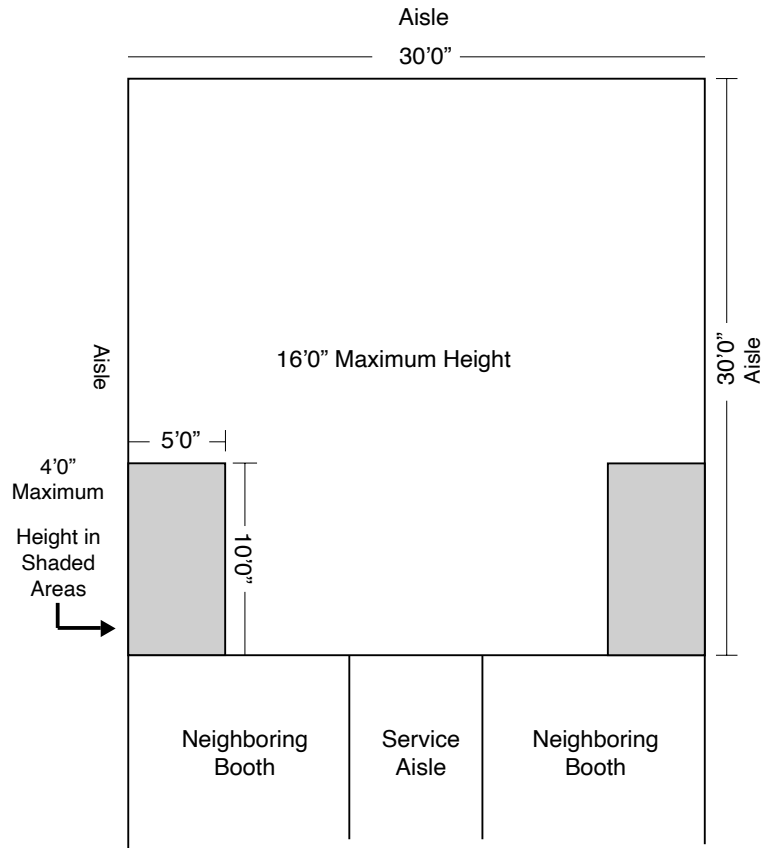

**SPLIT ISLAND BOOTH**

A split island booth is a peninsula booth that shares a common backwall with another peninsula booth. **The entire cubic content of this booth may be used up to the maximum content of 16’ (4.88m) including all exhibit fixtures. Hanging signs can be hung at a maximum height of 20’ (6.10m) to the top of the sign.** Backwalls must be finished and cannot contain copy.

Any Exhibitor occupying a split island booth is required to submit a detailed floor plan with dimensions, including height, of all items in the booth, including hanging signage, to Show Management for review and approval by July 2. Floor plans can be submitted through the Exhibitor Console or sent via email to [info@thenafemshow.org](mailto:info@thenafemshow.org).

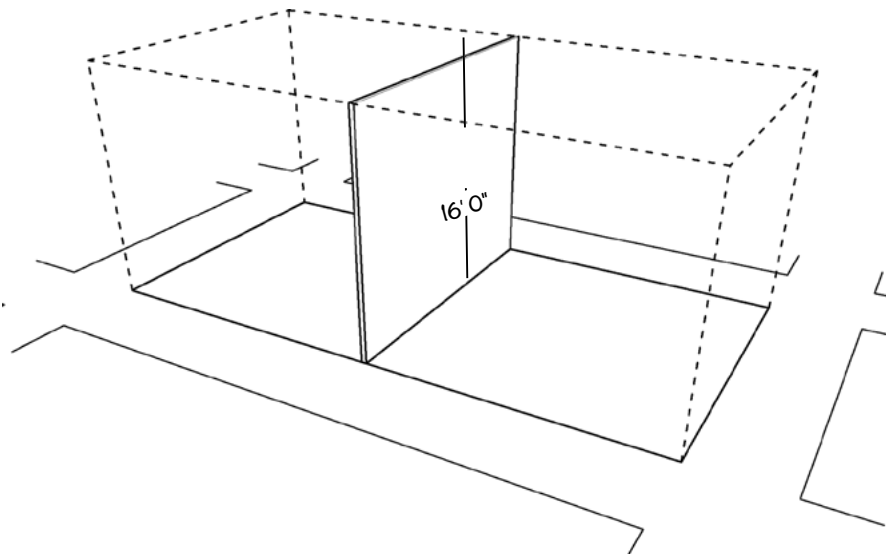

**MODIFIED PENINSULA BOOTH**

A modified peninsula booth is six (6) or more booths exposed on two (2) sides. Backwalls must be finished and cannot contain copy.

**Dimensions**

When a modified peninsula booth backs up to two (2) inline booths, the backwall is restricted to 4' (1.22m) in height within 5' (1.52m) of the aisle and 10' (3.05m) of the adjoining booths. **16' (4.88m) is the maximum height allowance for the center portion of the backwall and exhibit fixtures. Hanging signs can be hung at a maximum height of 20' (6.10m) to the top of the sign.** When a modified peninsula booth backs up to a peninsula booth(s), the backwall can be 16' (4.88m) along the entire section that adjoins the peninsula booth.

Any Exhibitor occupying a modified peninsula booth is required to submit a detailed floor plan with dimensions, including height, of all items in the booth, including hanging signage, to Show Management for review and approval by July 2. Floor plans can be submitted through the Exhibitor Console or sent via email to [info@thenafemshow.org](mailto:info@thenafemshow.org).

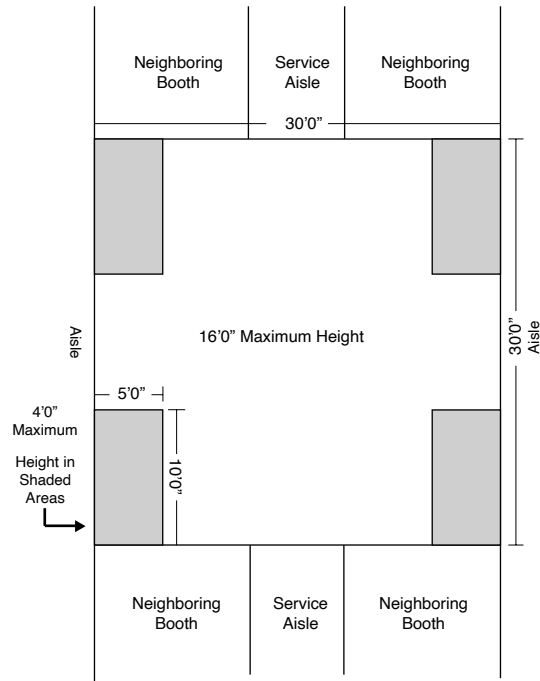

**ISLAND BOOTH**

An island booth is a booth that is 400 or more sq. ft. and exposed to aisles on all four (4) sides. **The entire cubic content of this booth may be used up to the maximum content of 16' (4.88m) Hanging signs can be placed at a maximum height of 20' (6.10m) to the top of the sign.**

Exhibitors wishing to create island booths smaller than those shown on the floor plan may do so for an additional \$3,000 aisle fee and two corner fees (\$250/corner). Exhibitors may delete booths from the floor plan to form an island, only if the total number of booths remaining on both sides of the aisle totals 400 sq. ft. or more (see diagram to the right).

Booth width must be less than or equal to booth length for any booth larger than 600 sq. ft.

Any Exhibitor occupying an island booth is required to submit a detailed floor plan with dimensions, including height, of all items in the booth, including hanging signage, to Show Management for review and approval by July 2. Floor plans can be submitted through the Exhibitor Console or sent via email to [info@thenafemshow.org](mailto:info@thenafemshow.org).

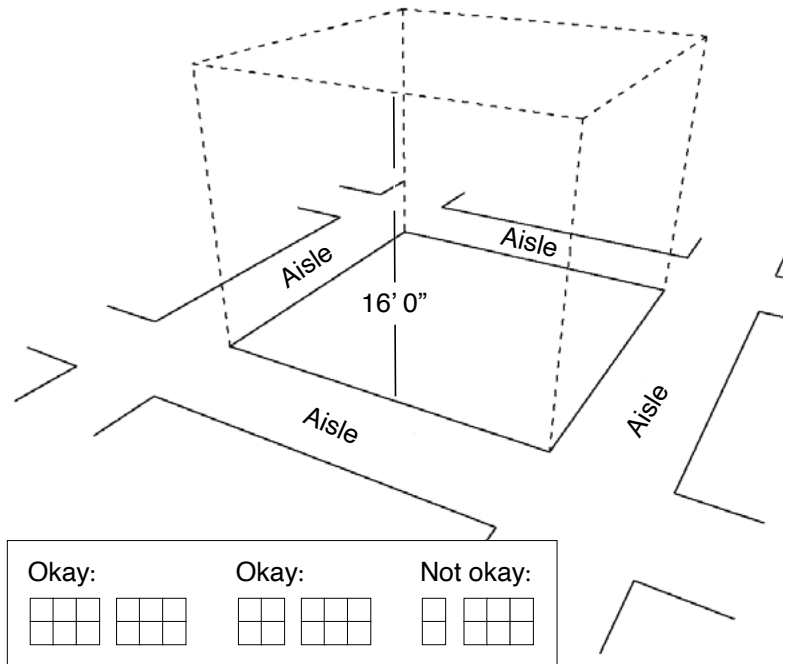

**CANOPIES & CEILINGS**

Canopies, including ceilings, umbrellas and canopy frames, can be either decorative or functional (such as to shade computer monitors from ambient light or for hanging products). Canopies for inline or perimeter booths should comply with line of sight requirements and may not protrude into the aisle.

The base of the canopy should not be lower than 7' (2.13m) from the floor within 5' (1.52m) of any aisle. Canopy supports should be no wider than 3" (7.62cm). This applies to any booth configuration that has a sightline restriction, such as an inline booth. Fire and safety regulations for the Orange County Convention Center may apply to canopies and ceilings and will be included in the Exhibitor Services Manual made available to Exhibitors in May. For an advance copy, contact Show Management by sending an e-mail to [info@thenafemshow.org](mailto:info@thenafemshow.org).

The Orange County Convention Center has reserved the right to update, change or amend its rules and regulations after publication in the Exhibitor Services Manual.

**HANGING SIGNS**

**Hanging signs are permitted in all peninsulas, modified peninsulas, split islands and island booths to a maximum height of 20' (6.10m) to the top of the sign. Hanging signs are NOT permitted in inline booths.** Whether suspended from above or supported from below, they should comply with all use-of-space requirements. When suspended from above, there must be a minimum of 12' (3.05m) of clearance from the floor to the bottom of the hanging sign unless there are items that prevent foot traffic going under the sign. If within 5' (1.53m) of an adjacent booth, and if the placement complies with the use-of-space requirements, the side facing the adjacent booth should be finished and not contain any copy.

All hanging equipment must be designed to suspend safely. A structural engineer's stamp of approval must be available upon request.

Any Exhibitor using hanging signs is required to submit a detailed floor plan, including dimensions and location of the sign, to Show Management for review and approval by July 2. Floor plans can be submitted through the Exhibitor Console or sent via email to [info@thenafemshow.org](mailto:info@thenafemshow.org).

An Exhibitor may list its NAFEM member company name and brands on hanging signs. Non-member Exhibitors may only list their company name on hanging signs.

**MULTI-STORY EXHIBITS**

A multi-story exhibit is permitted in all peninsulas, modified peninsulas, split islands and island booths to a maximum height of 16' (4.88m). Multi-story exhibits require approval and building permits from the Orange County Convention Center and the Orange County Fire Marshal. Exhibitors should obtain permits early on to ensure that all time constraints are met. Additional information is included in the Exhibitor Services Manual made available to Exhibitors in May. To obtain information in advance, contact Show Management at +1.312.245.1054 ext.5 or email [info@thenafemshow.org](mailto:info@thenafemshow.org).

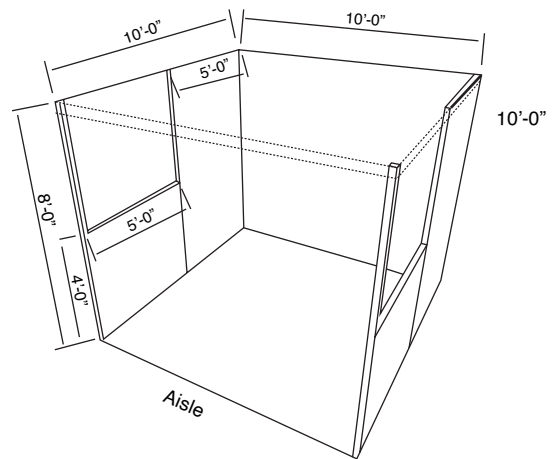

10'X10' INLINE BOOTH with Canopy

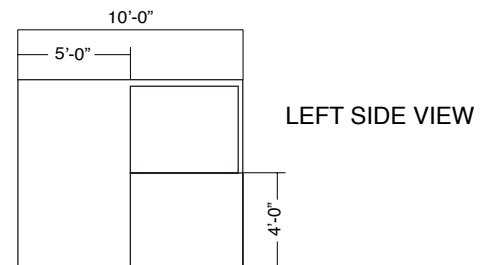

LEFT SIDE VIEW

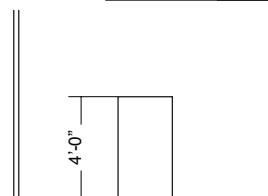

FRONT VIEW



## **STRUCTURAL INTEGRITY**

All exhibit displays should be designed and erected in a manner that will withstand normal contact or vibration caused by neighboring Exhibitors, hall laborers or installation/dismantling equipment such as fork lifts. Displays should be able to withstand moderate wind effects that may occur on the Show Floor when freight doors are open. Exhibitor should ensure that any display fixtures such as tables, racks or shelves are designed and installed properly to support the product or marketing materials to be displayed.

## **FLAMMABLE AND TOXIC MATERIALS**

All materials used in display construction and decorating should be made of fire retardant materials and be certified as flame retardant. Exhibitors should dispose of any waste products they generate during the exhibition in accordance with guidelines established by the Environmental Protection Agency (EPA) and the Orange County Convention Center.

## **STORAGE**

Fire regulations prohibit storing product, literature, empty packing containers or packing materials behind drapes. In most cases, however, Exhibitors may store a limited supply of literature or product appropriately within the booth area, as long as these items do not impede access to utility services, create a problem or look unsightly.